

Sharq™

**PRODUCT CATALOGUE
SHARQEDGES – EDGES
FOR GRADERS AND PLOWS**



**NEXT
GENERATION.
SHARQ EDGES
IN 600 HBW**



 **olofsfors**
Make your own way

► www.olofsfors.com

SHARQ TABLE OF CONTENTS

EDGES FOR GRADERS AND SNOW PLOWS

Benefits of the SharqEdges toolbox	4-5
SharqEdges Technique	6
Sharq FlexDesign	8
The Edges for all seasons	9

PRODUCTS

Sharq P300™ Original	10
Sharq Flat	11
Sharq P300™ HD	12
Sharq RAM™	13
Carbide Inserted Blades	14
HMS 3000™ and Stingers	15
Sharq Viking	16
Curb Protector c/c 305 mm	17
Mounting Boards	18
Mounting Hardware	19
Race 150	26

INSTRUCTIONS

Sharq Startup	20
Wedge mounting	22
Bolt mounting	23
Mounting instructions	24-25

BRUXITE BLADES 27-29

Customer Testimonials	30
-----------------------	----

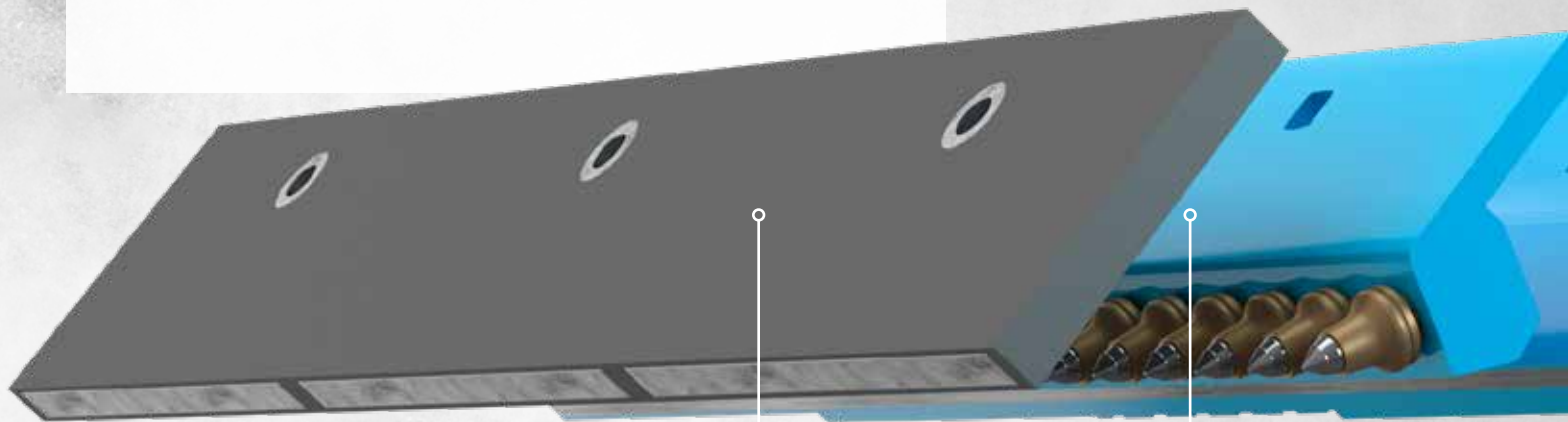

RACE 150

HMS 3000™ AND STINGERS

SHARQ

GENERATION

“The SharqEdges System is a universal quick mount system for all motor graders and snow plows with the unique sharp cutting system that save time and money for your operations.”

THE MOST COST EFFECTIVE CUTTING-EDGE SYSTEM FOR ALL SEASONS, AND ALL ROAD CONDITIONS.

Sharq™

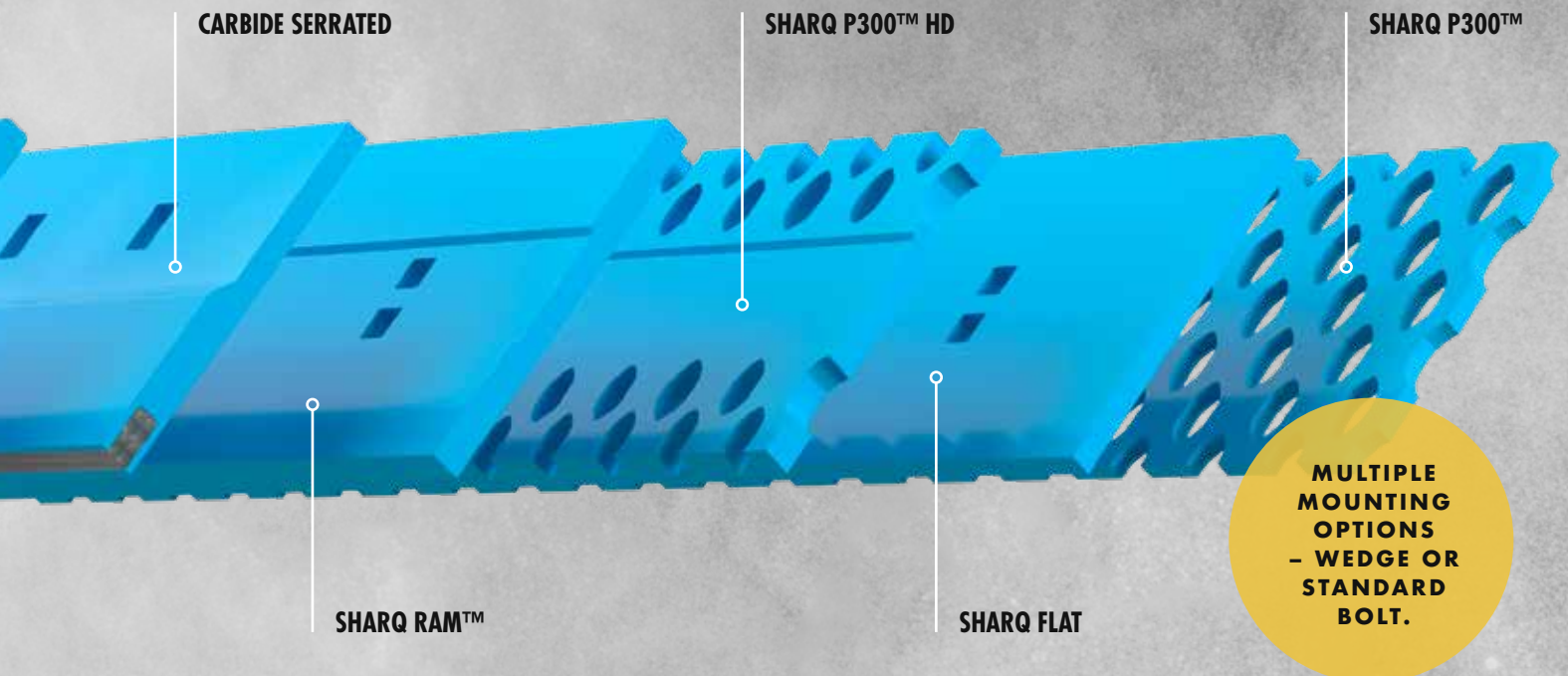

THE COMPLETE TOOLBOX OF CUTTING EDGES.

- + CONVERT ANY GRADER AND SNOW PLOW
- + EDGES FOR ROAD AND WEATHER CONDITIONS
- + SAVES YOU TIME AND MONEY
- + INCREASE ROAD SAFETY
- + INCREASE PRODUCTIVITY
- + MINIMIZE DOWNTIME WITH QUICK MOUNT SYSTEM
- + MAINTAIN SHARP AND STRAIGHT CUTTING EDGE THROUGH THE ENTIRE BLADE
- + IMPROVE OPERATOR ENVIRONMENT
- + USE LITTLE TO NO DOWN PRESSURE
- + REDUCE WEAR ON THE GRADER TIRES
- + REDUCED FUEL CONSUMPTION BY 20%–35%
- + RUN IN HIGHER GEAR & LOWER RPM
- + REDUCE TIME AND COSTS OF CHANGING EDGES



SHARQ BENEFITS

#1. REDUCED FUEL CONSUMPTION AND EMISSIONS. (20–35% SAVINGS)

Because:

- + Thinner/sharper edges require less down pressure and hence less power from the engine.
- + Run at higher gear and lower RPM.
- + Less/fewer passes.

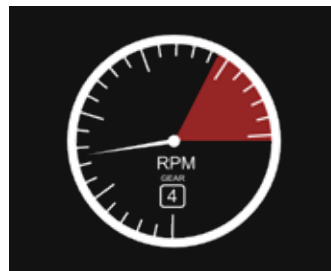

With Sharq



Without Sharq

#2. IMPROVED OPERATOR ENVIRONMENT.

Because:

- + Reduce chattering and noise in the cab.
- + Less vibration and less operator fatigue.



With Sharq



Without Sharq

#3. REDUCED WEAR AND TEAR ON THE MACHINE.

Because:

- + Less down pressure. = Less stress on the machine.
- + Longer tire life.
- + No rear diff lock required for traction
- + Mounting plate adds a layer of protection for the moldboard.



With Sharq



Without Sharq

#4. REDUCED TIME AND COST OF CHANGING EDGES.

Because:

- + No pneumatics required
- + Change and adjust blades with a hammer.
- + One person only to change the blades.
- + Change and adjust blades anywhere, on the road or on job site without returning to the garage.
- + Edges are light weight and easy to bring/mount spares to the grader.



Reduced downtime

#5. EDGES STAY SHARP.

Because:

- + Thin edges at the cutting angle will penetrate through the material.
- + Adjust the edges quickly to maintain a straight edge.
- + Out perform conventional grader edges.
- + Good for any road condition and weather condition.

SHARQEDGES TECHNIQUE

Sharq™

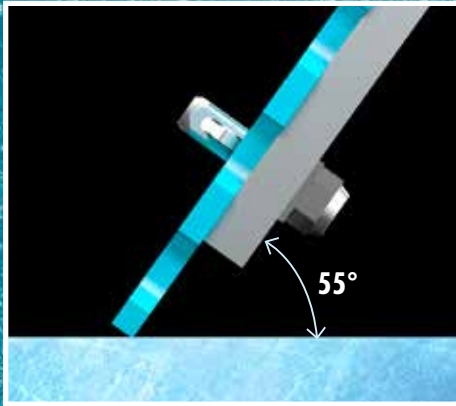

1 TILT THE EDGE BACK TO A MAXIMUM OF 55 DEGREES. CUT WITH THE LOWER CORNER.

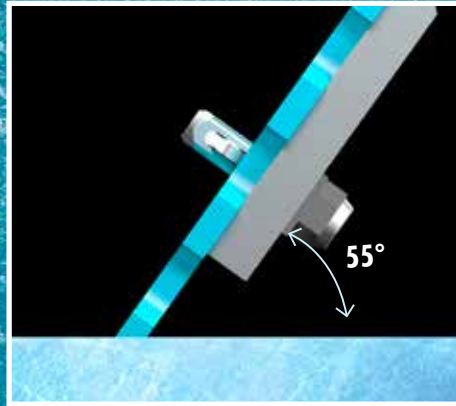

2 SHARPEN THE EDGE UNTIL IT'S BEVELED ALL THE WAY TO THE FRONT

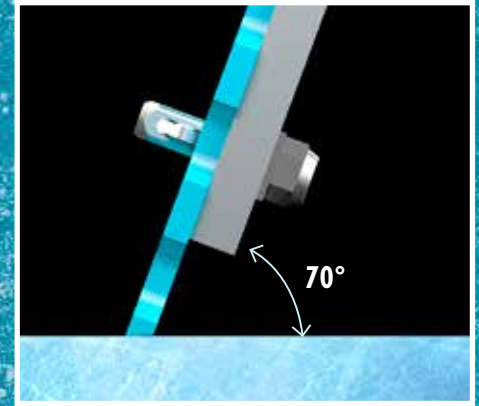

3 TILT THE MOLDBOARD FORWARD TO NO MORE THAN 70 DEGREES. CONTINUE CUTTING!

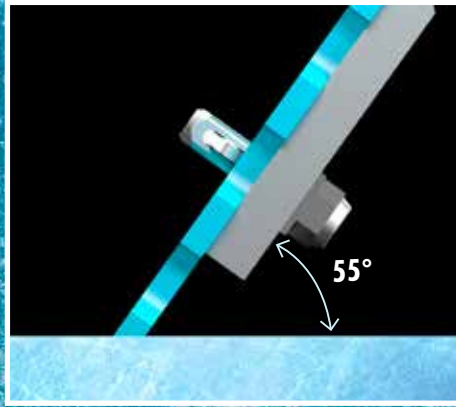

4 RESHARPEN THE EDGE BY TILTING THE EDGE BACK TO 55 DEGREES.

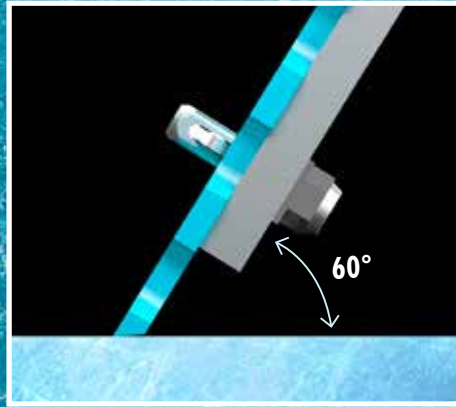

5 LIFT AND TILT FORWARD TO 60 DEGREES TO CUT MORE MATERIAL. NOT MUCH DOWN PRESSURE NEEDED.

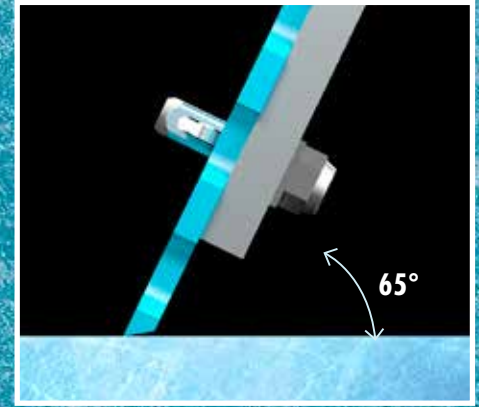

6 TILT FORWARD AGAIN TO 65 DEGREES AND CONTINUE CUTTING!

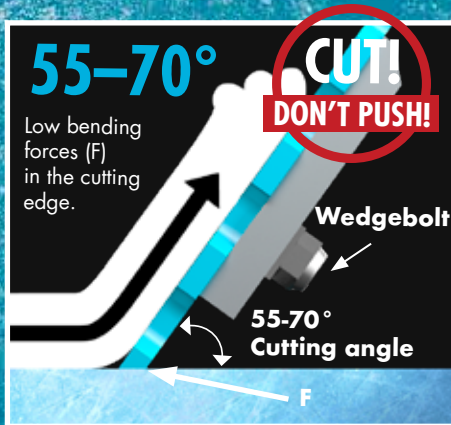

7 REGAIN A STRAIGHT EDGE LINE BY ADJUST THE EDGES AND MOVE THEM SIDE TO SIDE, UP AND DOWN. EXCHANGE THEIR PLACES ON THE MOLD BOARD. REMOUNTING IS DONE QUICKLY. MOUNT THE EDGE WITH A MAXIMUM 2" EXTENDING BELOW THE MOUNTING PLATE.



WHAT HAPPENS WHEN YOU OPERATE AT THE OPTIMAL CUTTING ANGLE WITH A THIN BLADE?

- + Maintain a sharp cutting edge allowing to penetrate your material
- + Get a good mix of fines from the cutting and rolling action
- + Use little to no down pressure relieving stress and over working the machine
- + Allow the machine to work in higher gears and lower RPM
- + Results in less fuel consumption and more KM/Miles per day

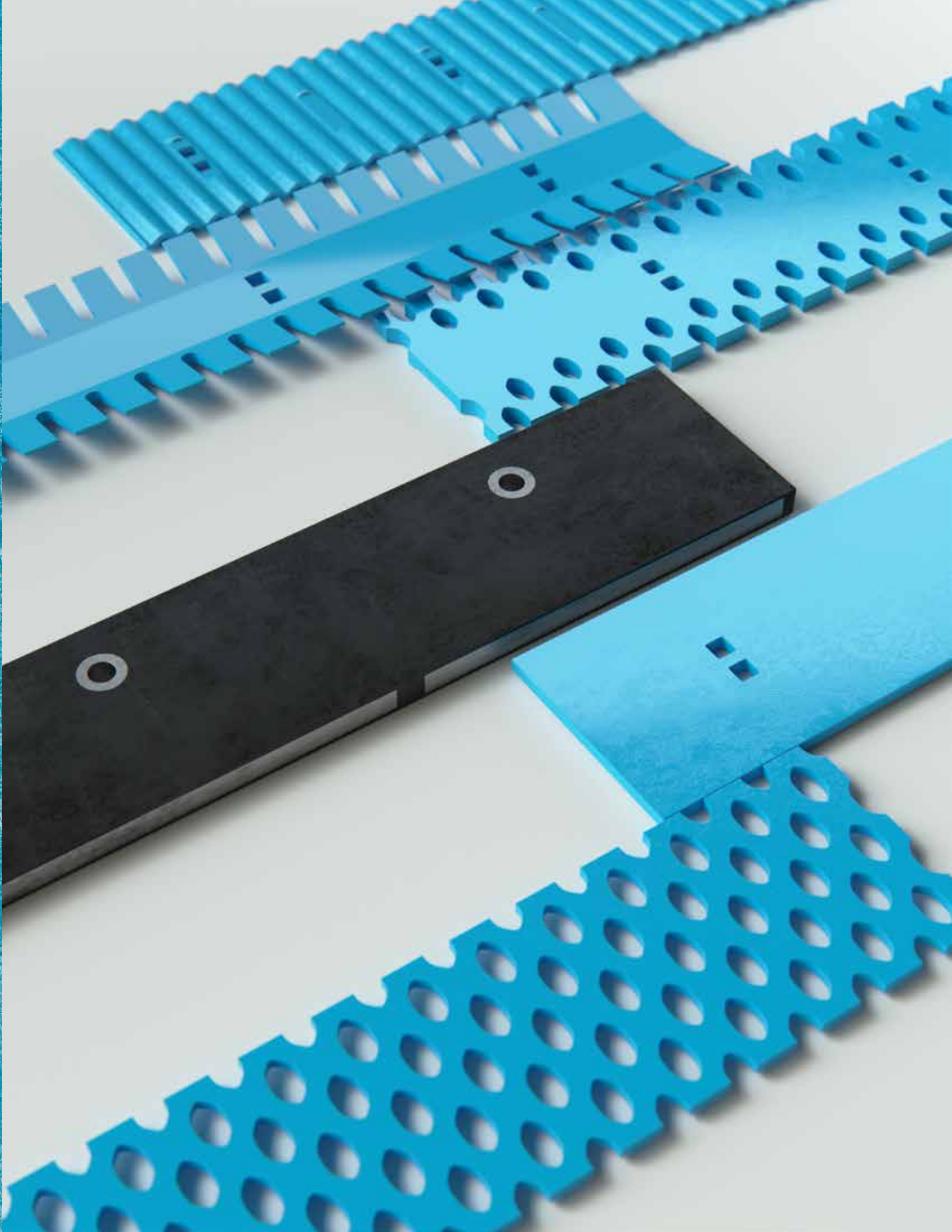

SHARQ FLEXDESIGN

- + Easy to recover a straight cutting edge by adjusting the blades.
- + Only takes 5–10 minutes to adjust contoured blades on the road side.
- + One person can easily and quickly make the adjustment back to a straight edge.
- + SHARQ edges can be moved vertically, horizontally, or flipped around.
- + Left-over blade after wear life, is less than 20%. Much less than any cutting edge.

The Sharq system is designed to be flexible and give maximum efficiency. The edges are light weight, easy to handle and can be mounted quickly.

With Sharq P300 and other double punched SharqEdges, it is easy to recover a straight cutting edge on the mold board. With a 5 minute stop on the road side you can solve the problem of a contoured edge line so you can run again with a straight edge line. No need to go back to the workshop to change blades. Saving time and fuel!

The Sharq FlexDesign makes road side edge changing quick and easy. All SharqEdges can easily be moved vertically, horizontally or flipped around so edges on the mold board are in a straight line.

We call this unique solution the **Sharq FlexDesign!**

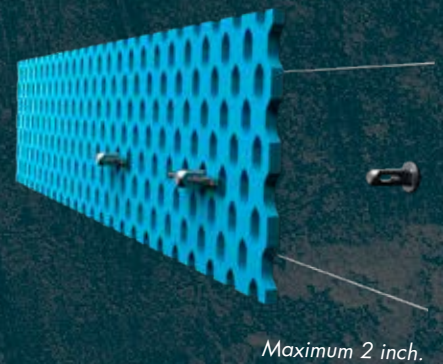

Maximum 2 inch.

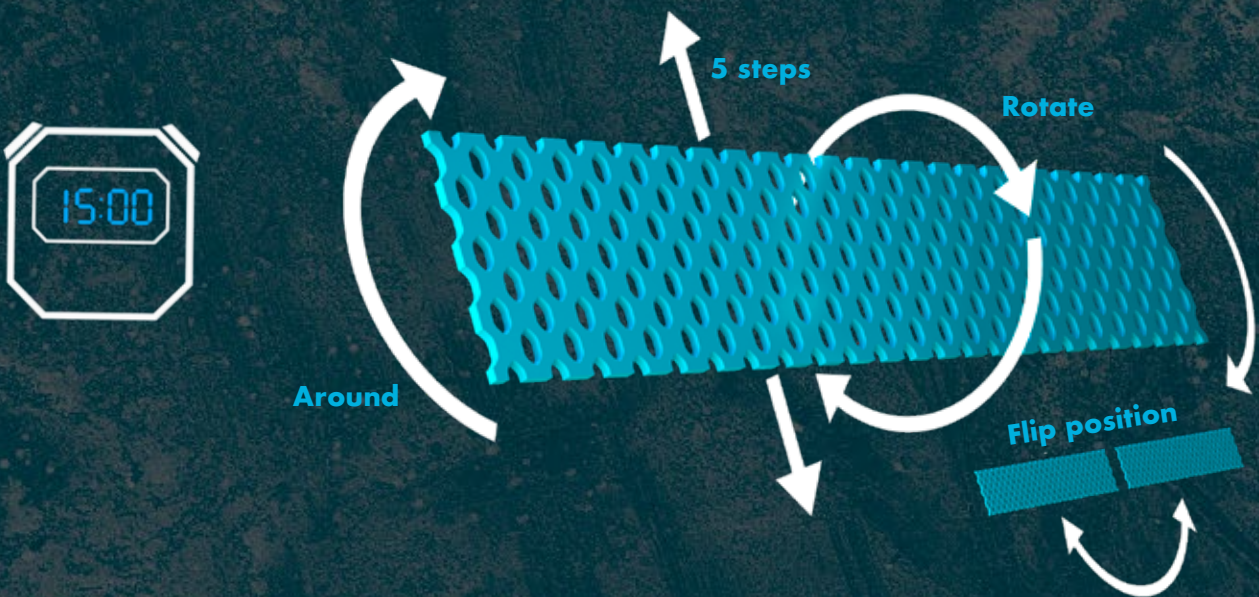



THE EDGES FOR ALL SEASONS

SUMMER MAINTENANCE

(Road Building and Maintenance on Gravel Roads)

- + Thin blade and sharp edge penetrates any material with little to no down pressure
- + Cuts through washboards and potholes and wheel ruts in less passes
- + The fines go through the holes of the blade, creating a good mix of materials in the road bed.
- + The roll of the material mixes the fines and redistributes them evenly across the road.
- + Results in a safe road that requires less maintenance.
- + Reduces the amount of time to revisit the road for maintenance.
- + Less down pressure reduces the need for the rear differential lock.
- + Select the P300 to cut and reshape the road, and use the flat to spread and pull ditches.
- + Choose 1 of the 8 compatible blades for your road conditions.

WINTER MAINTENANCE

(Ice and Snow Pack)

- + Cuts ice like no other blade. Thick chunks of ice can be removed with very little down pressure.
- + The P300 effectively rakes the ice and snow, leaving a perforated surface to allow sand or salt to react with the surface much quicker.
- + Salt and sand will fit in the groves left by the P300 and not get blown off the road from wind or traffic.
- + Reduce your costs on salt and sand consumption.
- + Thinner blades reduce the friction and heat transferred to the road to avoid creating a slippery surface.
- + Less down pressure reduces the need for tire chains to gain traction.

SHARQ P300™

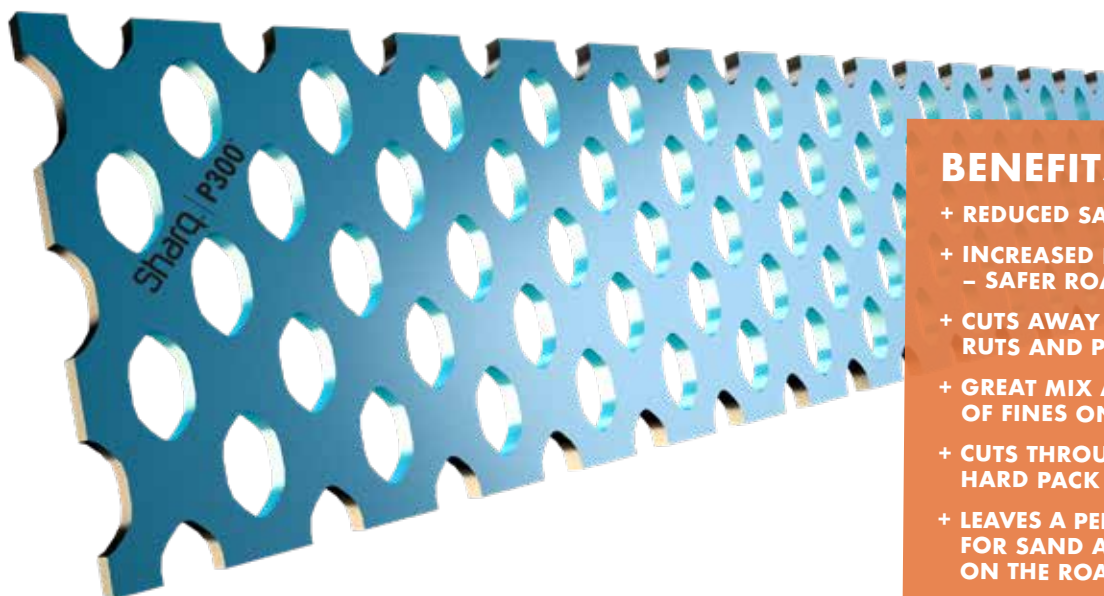

BENEFITS:

- + REDUCED SAND AND SALT COSTS
- + INCREASED ROAD FRICTION
– SAFER ROAD SURFACE
- + CUTS AWAY WASHBOARDS,
RUTS AND POT HOLES WITH EASE
- + GREAT MIX AND REDISTRIBUTION
OF FINES ON THE ROAD
- + CUTS THROUGH THICK ICE AND
HARD PACK SNOW
- + LEAVES A PERFORATED SURFACE
FOR SAND AND SALT TO REMAIN
ON THE ROAD

Sharq P300™ is the optimal edge to take care of snow compacted bumpy and polished winter roads. It easily cut up and straighten the white road surface and it makes grooves in the compacted snow and ice that helps sand and salt to stay on the road instead of it ending in the ditch. The snow and ice surface structure also get a much higher friction with Sharq P300 than with traditional flat blades.

You also know that thin, polished hard ice layer that makes the road rutted and slippery – Sharq P300 takes care of that. Run the Sharq P300 with the Sharq technique and you get straight down to a flat, non-slippery and safe road without any damage on the asphalt.

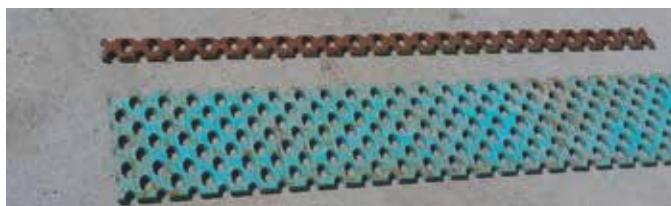

Item. No	W. mm	T. mm	L. mm	W. inches	T. inches	L. feet	Weight, kg	Weight, lbs	Note
122-454410	240	10	915	9,5	0,4	3	11,05	24,36	600 HBW
122-454420	240	10	1220	9,5	0,4	4	14,73	32,47	600 HBW
122-454430	240	10	1525	9,5	0,4	5	18,42	40,61	600 HBW

SHARQ FLAT

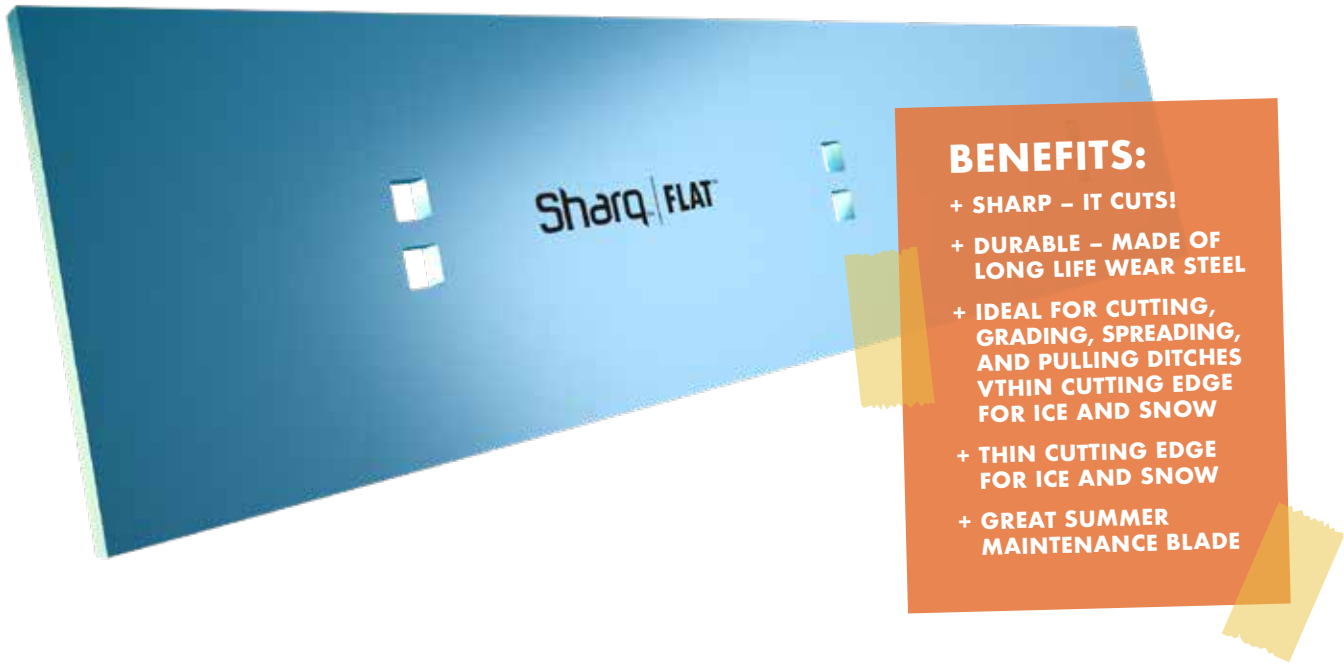

Sharq Flat is a universal grader edge made of Olofsfors extra long life wear steel. The reversible design makes it very cost effective. This edge is an excellent choice for general grading, mixing and snow removal.

The edge is made of high-strength through-hardened steel which makes it sharp and longlasting. The special steel alloy and thin design ensures maximum strength while minimizing the downward pressure required for optimum penetration. This increases carrier efficiency, reduces operating costs and allows better grader control. As with all the other SharqEdges these flat edges are quick mounting.



Item. No	W. mm	T. mm	L. mm	W. inches	T. inches	L. feet	Weight, kg	Weight, lbs	Note
122-454502	200	10	915	7,9	0,4	3	14,19	31,28	600 HBW
122-454512	200	10	1220	7,9	0,4	4	18,92	41,71	600 HBW
122-454522	200	10	1525	7,9	0,4	5	23,66	52,16	600 HBW
122-454692	200	12	915	7,9	0,4	3	17,03	37,54	600 HBW
122-454702	200	12	1220	7,9	0,4	4	22,71	50,07	600 HBW
122-454712	200	12	1525	7,9	0,4	5	28,39	62,59	600 HBW

Note: More edges available on request.

SHARQ P300™ HD

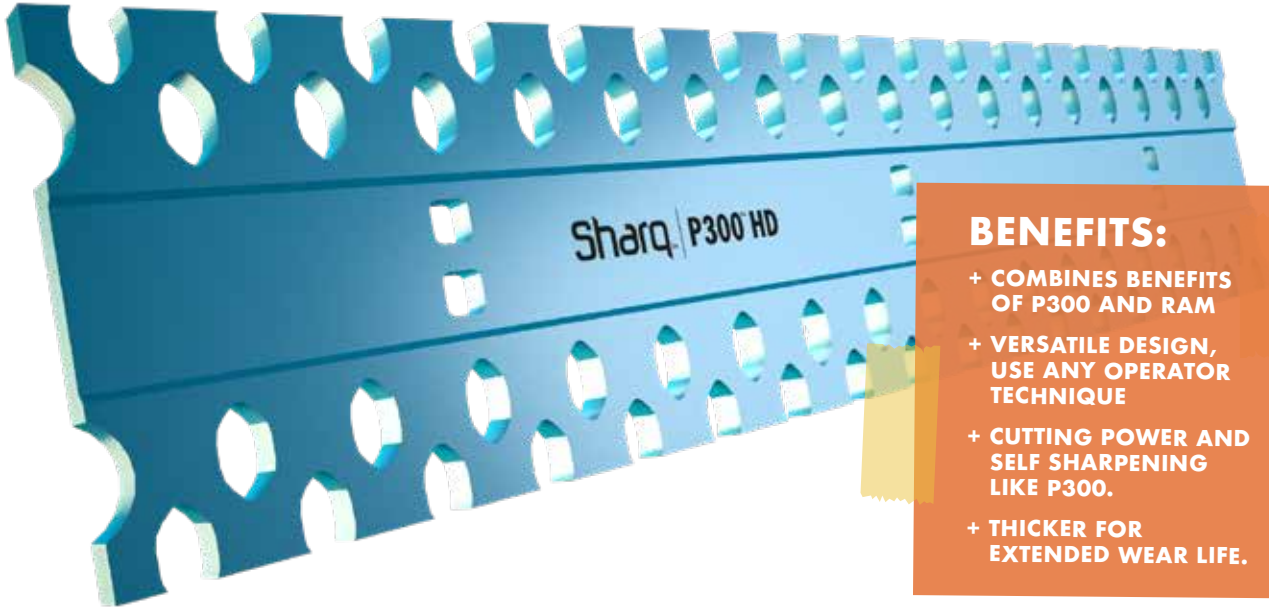

BENEFITS:

- + COMBINES BENEFITS OF P300 AND RAM
- + VERSATILE DESIGN, USE ANY OPERATOR TECHNIQUE
- + CUTTING POWER AND SELF SHARPENING LIKE P300.
- + THICKER FOR EXTENDED WEAR LIFE.

Sharq P300™ HD is a unique combination of the Sharq RAM and the Sharq P300. It's a serrated alternative to the Sharq RAM and a heavy duty alternative to the Sharq P300. With the same long life wear steel as the Sharq RAM and with the P300 teeth design it is as good for winter road maintenance as it is for hard gravel conditions.



Item. No	W. mm	T. mm	L. mm	W. inches	T. inches	L. feet	Weight, kg	Weight, lbs	Note
122-496434	200	16	915	7,9	0,63	3	16,73	36,88	550 HBW
122-496444	200	16	1220	7,9	0,63	4	22,30	49,16	550 HBW
122-496454	200	16	1525	7,9	0,63	5	27,89	61,49	550 HBW

SHARQ RAM™

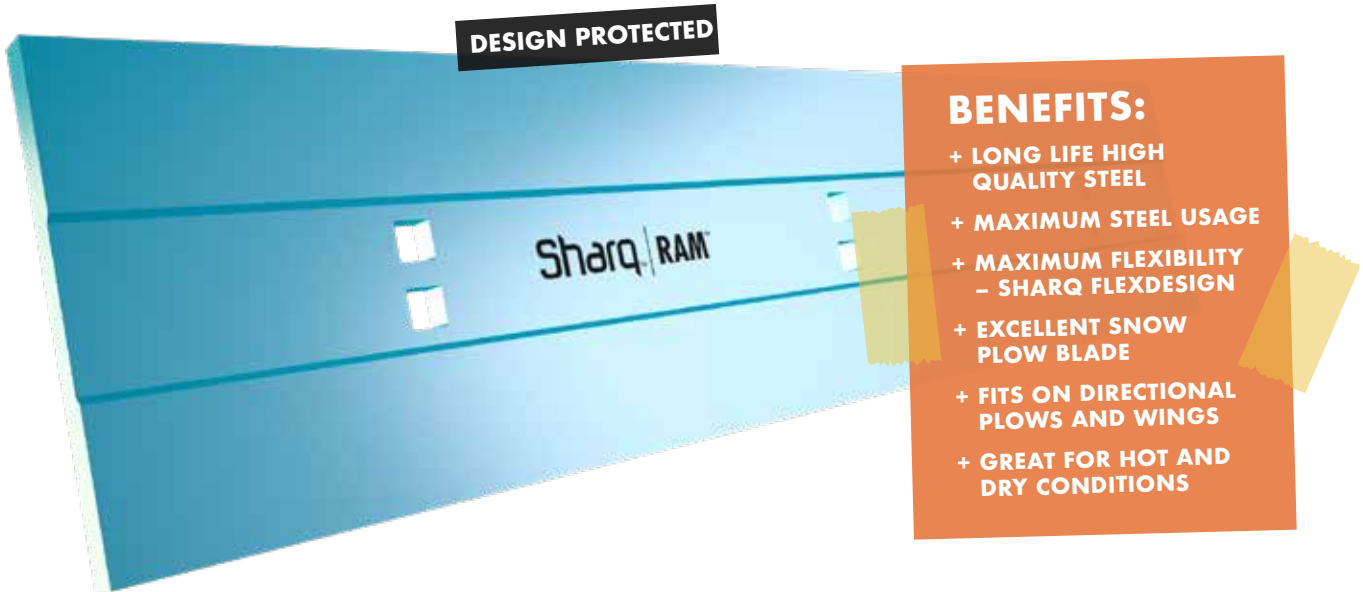

The **Sharq RAM™** edge beats all standard flat grader blades. With more steel to wear, long life high quality steel and the Sharq FlexDesign there is no reason to not convert your motor grader from standard grader blades to the Sharq-Edges system and the Sharq RAM. With Sharq RAM you can do everything that you do with standard grader blades – but at a reduced cost.

The Sharq RAM are available in 5/8" (16 mm) and 3/4" (20 mm) thicknesses.



Item. No	W. mm	T. mm	L. mm	W. inches	T. inches	L. feet	Weight, kg	Weight, lbs	Note
122-361971	200	16	915	7,9	0,63	3	21,33	47,02	550 HBW
122-361951	200	16	1220	7,9	0,63	4	28,45	62,72	550 HBW
122-361961	200	16	1525	7,9	0,63	5	35,57	78,42	550 HBW
122-361931	200	20	1220	7,9	0,79	4	33,31	73,44	550 HBW
122-361941	200	20	1525	7,9	0,79	5	41,64	91,80	550 HBW

CARBIDE INSERTED BLADES

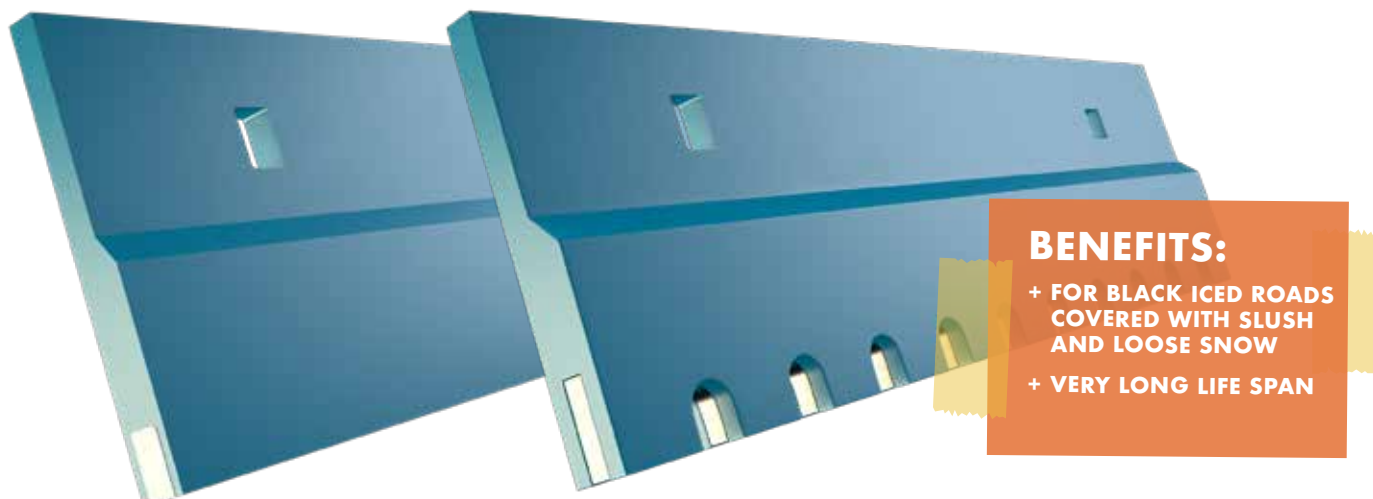

Olofsfors carbide inserted blades for plowing slush and compact snow are designed to resist fracture and wear damage. Due to the thickness of the blade the cutting effect is less but the thick cutting surface and the brazed carbide give the blade a very long life span.

The carbide inserted blades consist essentially of ordinary steel in which carbide bits have been bazed into it which makes them harder than the hardest wear steel.

CARBIDE INSERTED BLADES C/C 305 MM

Item. No	W. mm	T. mm/mm	L. mm	W. inches	T. inches	L. feet	Weight, kg	Weight, lbs	Note
920-461810	130	20/12	610	5,12	0.78/0.47	2	9,10	20,06	Carbide bits hardness approx. 87 HRA
920-461820	130	20/12	915	5,12	0.78/0.47	3	15,25	33,62	Carbide bits hardness approx. 87 HRA
920-461830	130	20/12	1220	5,12	0.78/0.47	4	20,00	44,09	Carbide bits hardness approx. 87 HRA

SERRATED CARBIDE INSERTED BLADES C/C 305 MM

Item. No	W. mm	T. mm/mm	L. mm	W. inches	T. inches	L. feet	Weight, kg	Weight, lbs	Note
920-461850	130	20/12	610	5,12	0.78/0.47	2	9,00	19,85	Carbide bits hardness approx. 87 HRA
920-461860	130	20/12	915	5,12	0.78/0.47	3	13,00	28,67	Carbide bits hardness approx. 87 HRA
920-461870	130	20/12	1220	5,12	0.78/0.47	4	18,00	39,69	Carbide bits hardness approx. 87 HRA

HMS 3000™ AND STINGERS

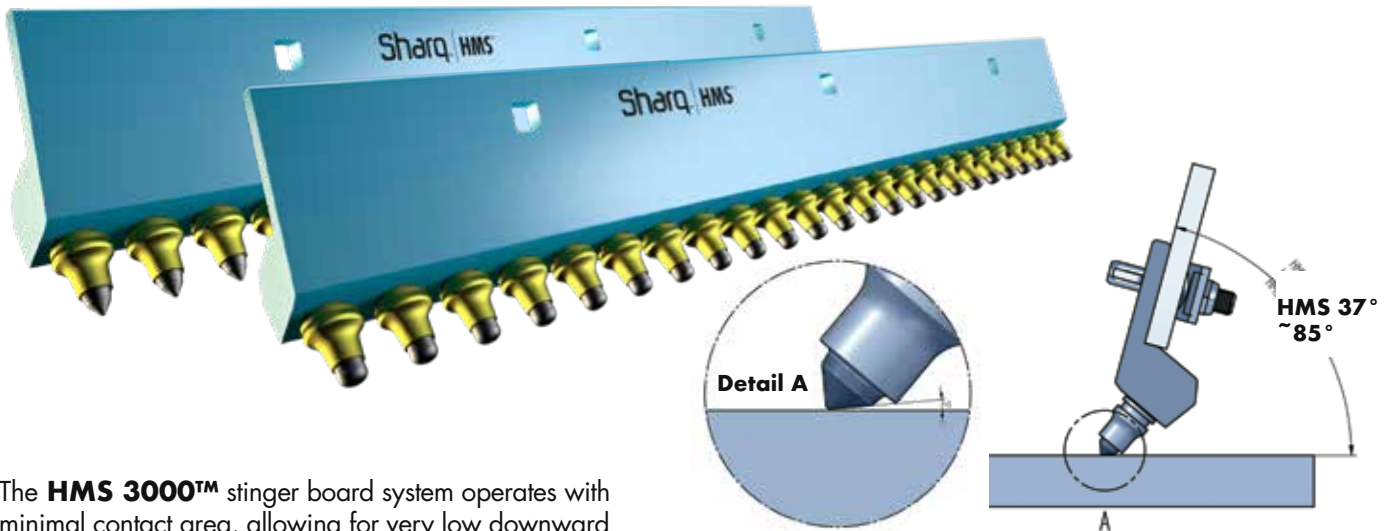

The **HMS 3000™** stinger board system operates with minimal contact area, allowing for very low downward pressure on the edge. The HMS 3000 board comprises one solid piece with integrated support for maximum stability. The stinger bit holes are drilled with high precision to ensure the stingers can rotate reliably and will wear evenly throughout their lifetime. The HMS 3000 is not welded.

The HMS 3000 system protects the grader better and is far stronger than stinger boards with individually welded adapters for each stinger. If some stingers take an impact from a manhole, for instance the wedge bolts break to protect the grader and the solid stinger board remains undamaged.

Note: Both wedges 20,5 x 125 and 18,5 x 100 can be used. For severe duty 18,5 is recommended.

Carbide bits must be at 45° with the road surface. Carbide bits will rotate while in operation to cut the material.

Item. No	L. mm	L. feet		Weight, kg	Weight, lbs	Note
122-164092	912	3	37° Ø 22,3 mm	20,00	44,09	500 HBW (52 Rockwell "C")
122-164095	1217	4	37° Ø 22,3 mm	27,00	59,52	500 HBW (52 Rockwell "C")
122-158004	608	2	37° Ø 19,5 mm	16,00	35,27	500 HBW (52 Rockwell "C")
122-158002	912	3	37° Ø 19,5 mm	20,00	44,09	500 HBW (52 Rockwell "C")
122-158005	1217	4	37° Ø 19,5 mm	26,00	57,32	500 HBW (52 Rockwell "C")
122-156070	605	2	25° Ø 19,5 mm	15,00	33,07	500 HBW (52 Rockwell "C")
122-156071	915	3	25° Ø 19,5 mm	20,00	44,09	500 HBW (52 Rockwell "C")
122-156072	1220	4	25° Ø 19,5 mm	26,00	57,32	500 HBW (52 Rockwell "C")
122-156085	1217	4	25° Ø 25,0 mm	48,50	106,92	500 HBW (52 Rockwell "C")
920-450396		0,765	Ø 19,5 mm	0,27	0,60	Carbide Stud, sharp with collar and washer
920-450395		0,765	Ø 19,5 mm	0,27	0,60	Carbide Stud, blunt with collar and washer

SHARQ VIKING

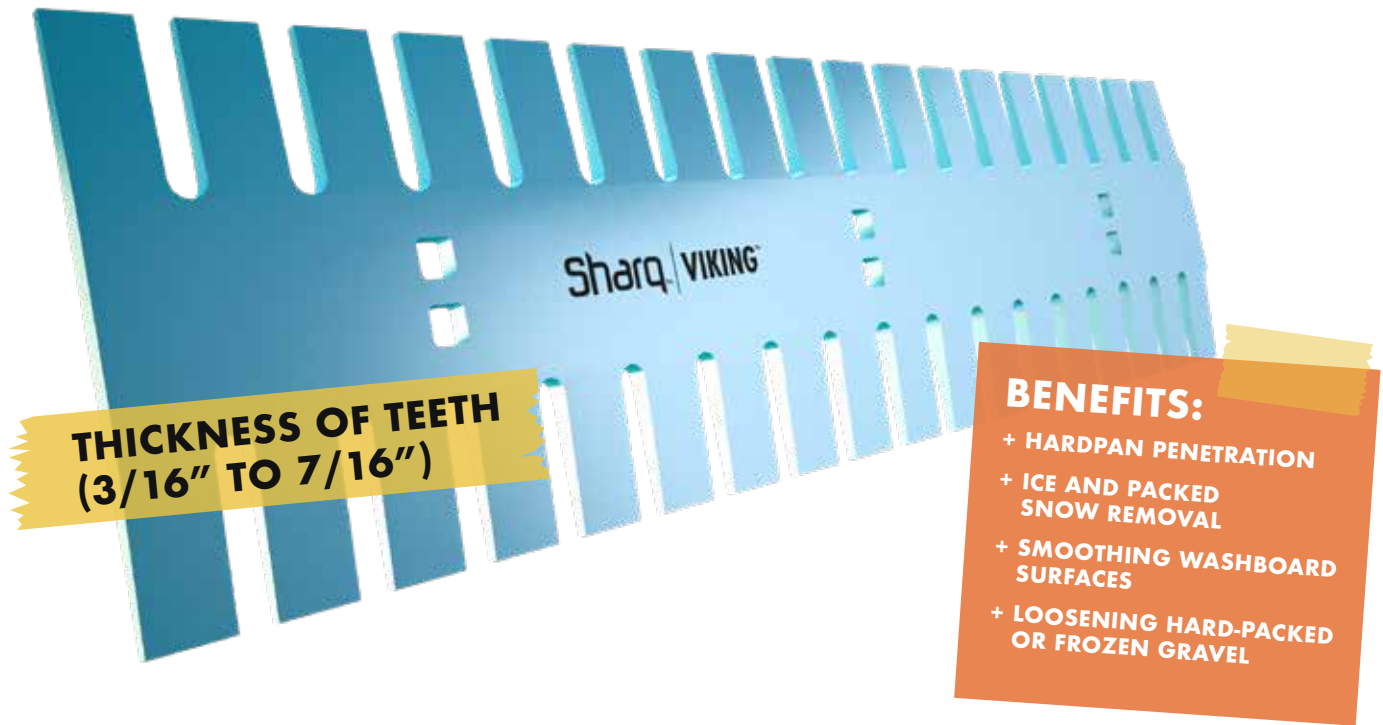

The **Sharq Viking** edge provides ultimate penetration in all ice conditions. With its long, thin, hard and tough teeth you can do ice removal that you always believed was impossible. The Viking edge can also be used for loosening frozen ground or gravel. Like most other SharqEdges, the serrated edge is reversible, so it's really two edges in one.



Item. No	W. mm	T. mm	L. mm	W. inches	T. inches	L. feet	Weight, kg	Weight, lbs	Note
122-483320	240	11	1220	9,5	0,43	4	17,21	37,94	500 HBW
122-483330	240	11	1525	9,5	0,43	5	21,52	47,44	500 HBW

CURB PROTECTOR

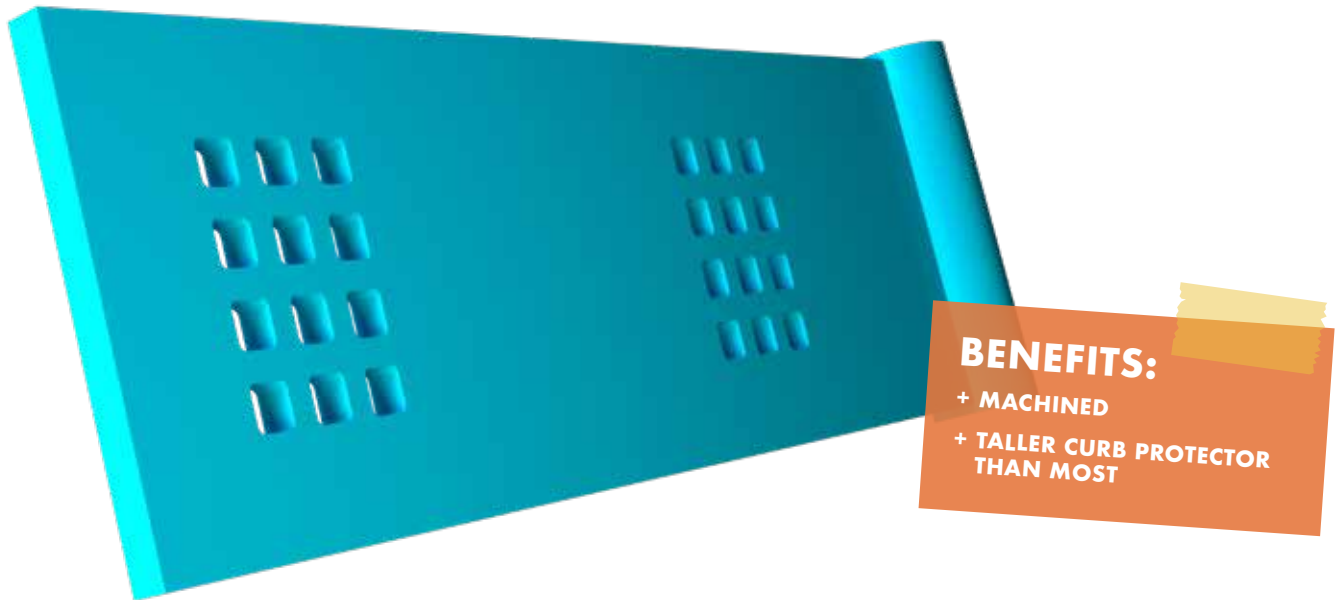

Olofsfors curb protector has a classic Canadian design. It's made of the same special alloy steel as the SharqEdges and heat-treated using the same process that makes SharqEdges so strong and durable. Use wedgebolt 65 mm.



Item. No	W. mm	T. mm	L. mm	W. inches	T. inches	L. feet	Weight, kg	Weight, lbs	Holes	Note
122-484100	260	16	580	10,2	0,63	22,8	19,00	41,89	2x(4x3)	Ø = 60 mm (2 ^{3/8} ") 475 HBW

MOUNTING BOARDS

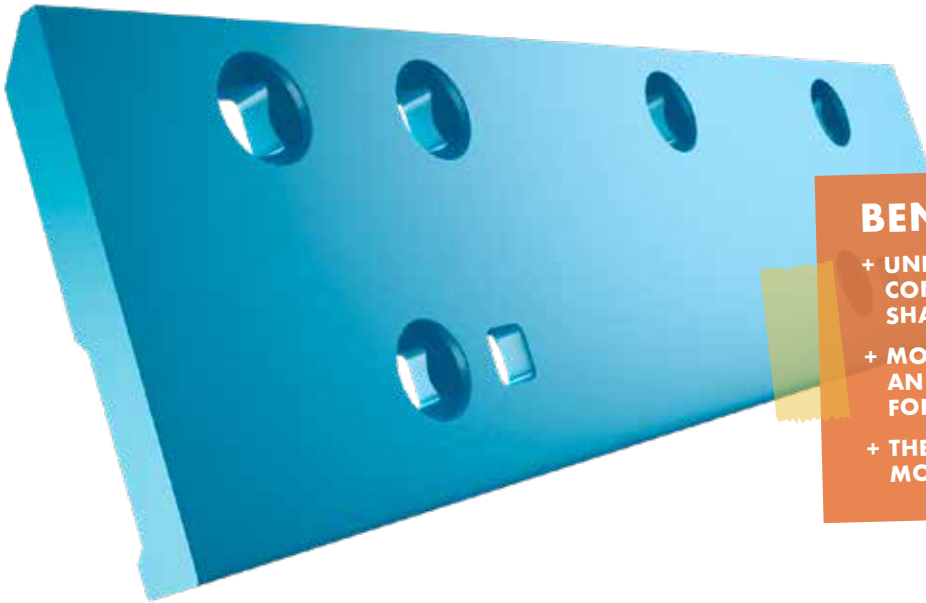

BENEFITS:

- + UNIVERSAL MOUNTING BOARDS CONVERT ANY GRADER TO SHARQEDGES SYSTEM.
- + MOUNTING BOARD PROVIDES AN EXTRA LAYER OF PROTECTION FOR THE MOLDBOARD.
- + THE KEY BEHIND THE QUICK MOUNT SYSTEM.

Olofsors provides **mounting boards** to convert any motor grader to Sharqedges. Most common are 7 and 8 foot lengths with either 5/8-inch or 3/4-inch mounting holes. With a mounting board fitted, you have full access to the complete system of quickmounted edges for all road conditions and seasons.



Item. No	W. mm	T. mm	L. mm	W. inches	T. inches	L. feet	Weight, kg	Weight, lbs	c/c	Fastening hole	Note
122-369570	150	20	1512	5,9	0,79	5	33,00	72,75	305/305	5/8"	Wedgebolt 53
122-369560	150	20	1512	5,9	0,79	5	32,00	70,55	305/305	3/4"	Wedgebolt 53
122-369550	150	20	1817	5,9	0,79	6	39,00	85,98	305/305	5/8"	Wedgebolt 53
122-369540	150	20	1817	5,9	0,79	6	39,00	85,98	305/305	3/4"	Wedgebolt 53
122-369530	150	20	2122	5,9	0,79	7	46,00	101,41	305/305	5/8"	Wedgebolt 53
122-369520	150	20	2122	5,9	0,79	7	46,00	101,41	305/305	3/4"	Wedgebolt 53
122-369510	150	20	2427	5,9	0,79	8	53,00	116,84	305/305	5/8"	Wedgebolt 53
122-369500	150	20	2427	5,9	0,79	8	52,00	114,64	305/305	3/4"	Wedgebolt 53

MOUNTING HARDWARE

WEDGE BOLTS

Item No.	Designation	W. mm	L. mm	W. inches	L. inches	Weight kg	Weight lbs	Note
151-457510	Wedge Bolt 53	16	53	0,6	2,1	0,14	0,30	25 pcs/pack
151-457500	Wedge Bolt 47	16	47	0,6	1,9	0,12	0,26	25 pcs/pack
151-457512	Wedge Bolt 65	16	65	0,6	2,6	0,16	0,35	24 pcs/pack



WEDGES

Item No.	Designation	L. mm	L. inches	Weight kg	Weight lbs	Note
151-455980	20,5 long	125	4,9	0,09	0,20	50 pcs/pack, general service
151-455950	18,5	100	3,9	0,07	0,15	25 pcs/pack, severe duty up to 12-13 mm
151-455960	20,5	100	3,9	0,07	0,15	50 pcs/pack, severe duty up to 11 mm



MOUNTING TOOLS

Item No.	Designation	Weight kg	Weight lbs	Note
151-484320	Mounting tool with shatter protection	1,10	2,43	



BOLTS

Item No.	Designation			Weight kg	Weight lbs	Note
959-590300	M16X37 (5/8" x 1-1/2")	FH	Qual. 10.9	0,07	0,15	25 pcs/pack
959-590310	M16X65 (5/8" x 2-1/2")	FH	Qual. 12.9	0,10	0,22	25 pcs/pack
950-500620	M16X35 (5/8" x 1-3/8")	M6S	Qual. 8.8	0,06	0,13	25 pcs/pack
959-590270	M16X45 (5/8" x 1-3/4")	KH	Qual. 12.9	0,11	0,23	25 pcs/pack
959-590285	M16x55 (5/8" x 2-1/4")	KH	Qual 12.9	0,12	0,26	25 pcs/pack.
959-590730	M20X65 (3/4" x 2-1/2")	FH	Qual. 10.9	0,15	0,33	25 pcs/pack



NUTS

Item No.	Designation		Weight kg	Weight lbs	Note
959-590360	M16	Locking nut	0,04	0,09	
959-590670	M20	Locking nut	0,06	0,13	



WASHERS

Item No.	Designation	W x T x L mm	W x T x L inches	Weight kg	Weight lbs	Note
959-590250	No 70 – straight	30 x 6 x 70	1,2 x 0,24 x 2,8	0,09	0,20	24 pcs/pack
959-590560	No 80,65-sliding	40 x 6 x 130	1,6 x 0,24 x 5,1	0,20	0,44	20 pcs/pack





SHARQ STARTUP

Sharq P300	Sharq RAM 16 mm	Sharq RAM 20 mm	Sharq P300 HD
10ft: 122-454430=2 pcs	10ft: 122-361961=2 pcs	10ft: 122-361941=2 pcs	10ft: 122-496454=2 pcs
11ft: 122-454420=2 pcs 122-454410=1 pc	11ft: 122-361951=2 pcs 122-361971=1 pc	11ft: 122-361931=2 pcs 122-362101=1 pc	11ft: 122-496444=2 pcs 122-496434=1 pc
12ft: 122-454420=3 pcs	12ft: 122-361951=3 pcs	12ft: 122-361931=3 pcs	12ft: 122-496444=3 pcs
13ft: 122-454420=2 pcs 122-454430=1 pc	13ft: 122-361951=2 pcs 122-361961=1 pc	13ft: 122-361931=2 pcs 122-361941=1 pc	13ft: 122-496444=2 pcs 122-496454=1 pc
14ft: 122-454420=1 pc 122-454430=2 pcs	14ft: 122-361951=1 pc 122-361961=2 pcs	14ft: 122-361931=1 pc 122-361941=2 pcs	14ft: 122-496444=1 pc 122-496454=2 pcs
16ft: 122-454420=4 pcs	16ft: 122-361951=4 pcs	16ft: 122-361931=4 pcs	16ft: 122-496444=4 pcs

Number of parts needed for each mounting board

Sharq bolt-mounting	10 ft. M16	10 ft. M20	11 ft. M16	11 ft. M20	12 ft. M16	12 ft. M20	13 ft. M16	13 ft. M20	14 ft. M16	14 ft. M20	16 ft. M16	16 ft. M20
Adapter-plates M16, 5 ft., 122-369570	2		1									
Adapter-plates M16, 6 ft., 122-369550			1		2		1					
Adapter-plates M16, 7 ft., 122-369530							1		2			
Adapter-plates M16, 8 ft., 122-369510											2	
Adapter-plates M20, 5 ft., 122-369560		2		1								
Adapter-plates M20, 6 ft., 122-369540				1		2		1				
Adapter-plates M20, 7 ft., 122-369520								1		2		
Adapter-plates M20, 8 ft., 122-369500												2
Bolt FH M16x65, 959-590310	22		24		26		28		30		34	
Bolt FH M20x65, 959-590730		22		24		26		28		30		34
Nut M16 locking, 959-590350	32	10	35	11	38	12	41	13	44	14	50	16
Nut M20 locking, 959-590670		22		24		26		28		30		34
Support washer 80.65, 959-590560	10	10	11	11	12	12	13	13	14	14	16	16
Bolt FH M16x50, 959-590420	10	10	11	11	12	12	13	13	14	14	16	16
For mounting of the SharqEdges												
Wedge bolt 53, 151-457510	10	10	11	11	12	12	13	13	14	14	16	16
Wedge 20,5, 151-455980	10	10	11	11	12	12	13	13	14	14	16	16
Optional												
Bolt KH M16x55, 959-590285	10	10	11	11	12	12	13	13	14	14	16	16
Nut M16 locking, 959-590350	10	10	11	11	12	12	13	13	14	14	16	16

GENERAL TERMS

We reserve the right to make design changes at any time. This catalogue mainly contains our standard range of products. Other products are available on request. We reserve the right to make immediate corrections to any errors in the catalogue.

Sharq™

INSTRUCTIONS

► The Sharp Quick Mount Edge System

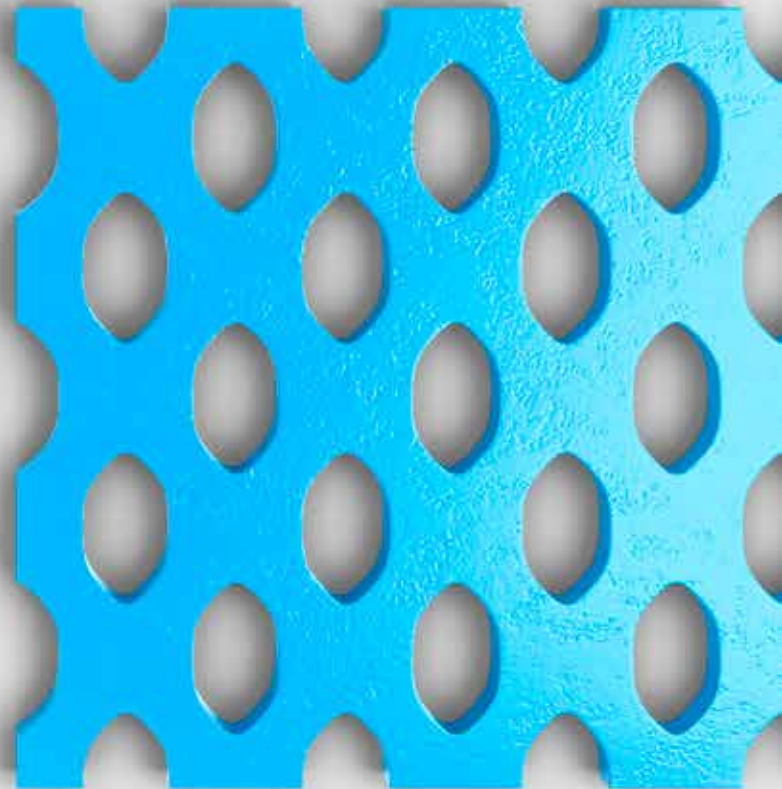
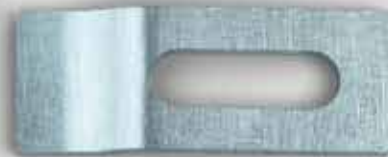
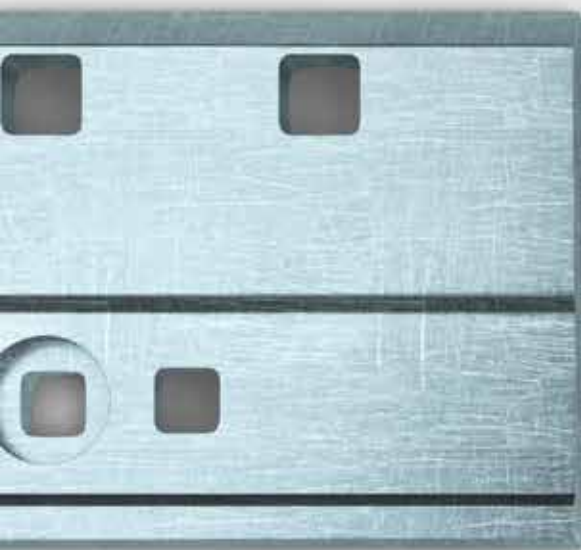

WEDGE MOUNTING INSTRUCTIONS FOR MOLDBOARD 3/4" AND 5/8"

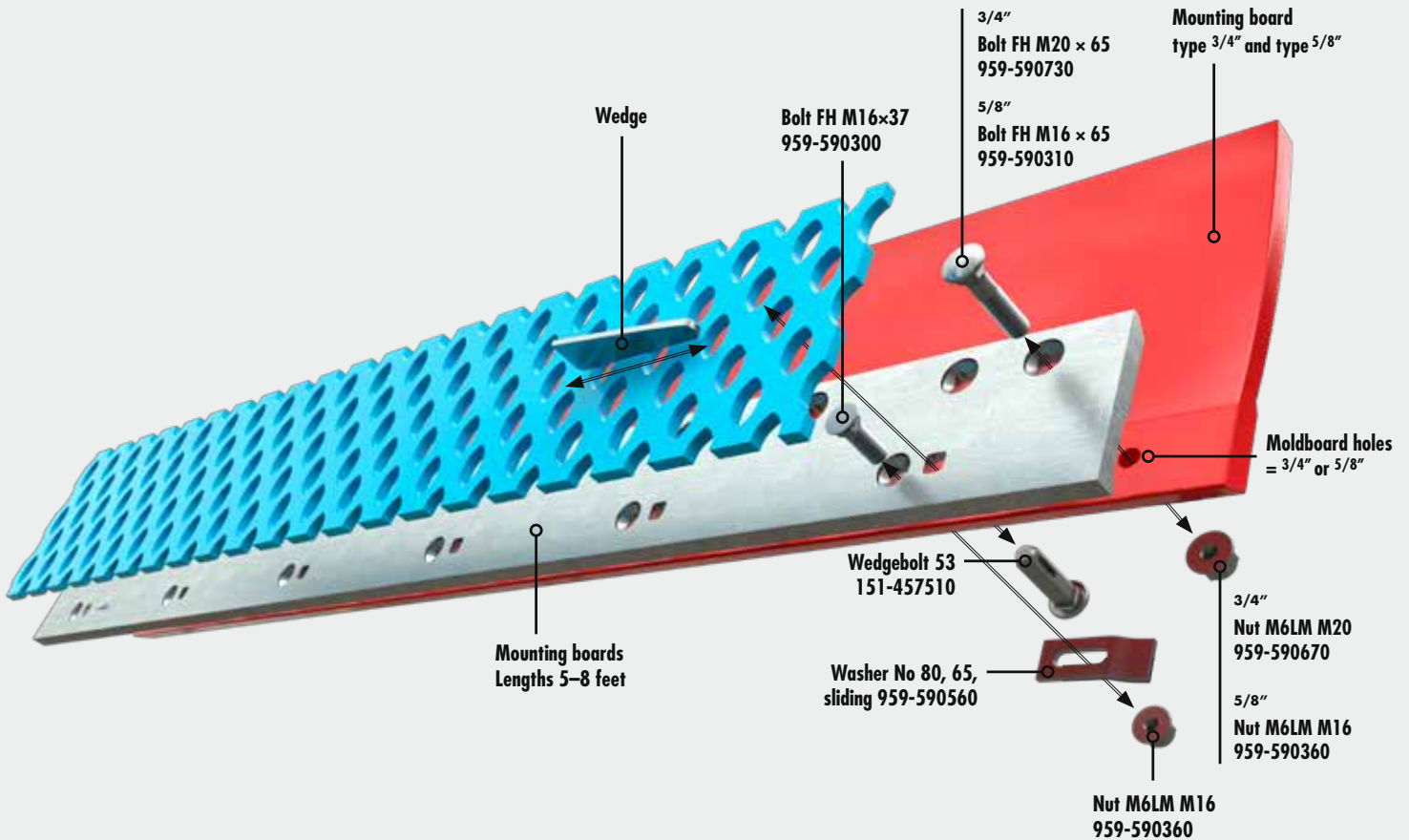

Number of parts needed for each mounting board.

For blades <11mm, use wedge 20,5 (151-455980) or 20,5 (151-455960).
For blades >12mm, use wedge 20,5 (151-455980) or 18,5 (151-455950).

Note: FH M20 = FH 3/4" with 5/8" head

Length	Adapter plate	Wedge	Wedgebolt 53	Washer no 80,65	Bolt FH M16 x 37	Nut M16 locking	Bolt FH M20x65	Nut M20 locking
5 feet	122-369560	5 x	5 x	5 x	5 x	5 x	11 x	11 x
6 feet	122-369540	6 x	6 x	6 x	6 x	6 x	13 x	13 x
7 feet	122-369520	7 x	7 x	7 x	7 x	7 x	15 x	15 x
8 feet	122-369500	8 x	8 x	8 x	8 x	8 x	17 x	17 x

Note: FH M16 = FH 5/8"

Length	Adapter plate	Wedge	Wedgebolt 53	Washer no 80,65	Bolt FH M16 x 37	Nut M16 locking	Bolt FH M16x65	Nut M16 locking
5 feet	122-369570	5 x	5 x	5 x	5 x	5 x	11 x	11 x
6 feet	122-369550	6 x	6 x	6 x	6 x	6 x	13 x	13 x
7 feet	122-369530	7 x	7 x	7 x	7 x	7 x	15 x	15 x
8 feet	122-369510	8 x	8 x	8 x	8 x	8 x	17 x	17 x

BOLT MOUNTING INSTRUCTIONS FOR MOLDBOARD 3/4" AND 5/8"

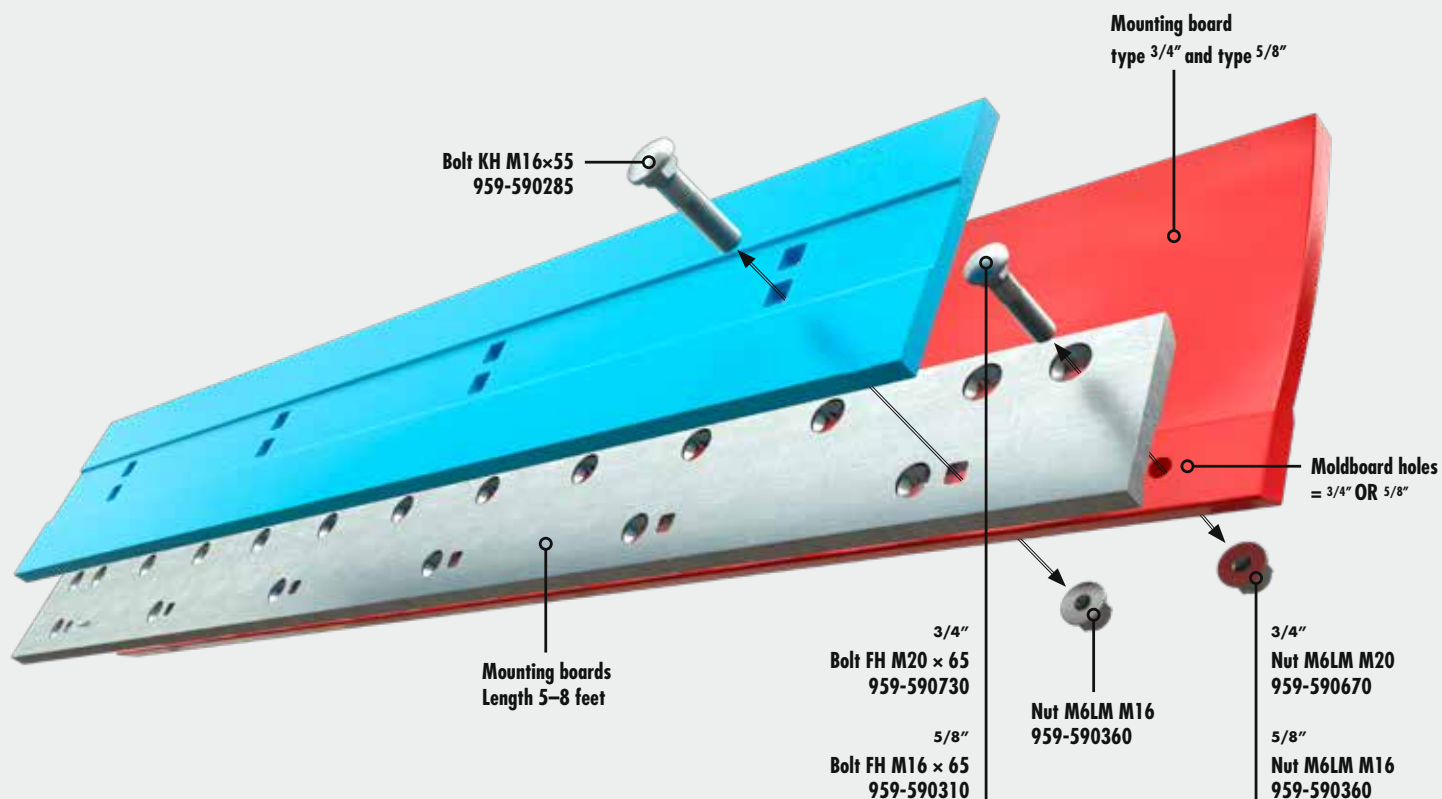

Number of parts needed for each mounting board.

Bolt Mounting 3/4

Length	Adapter Plate	Bolt KH M16 x 55	Nut M16 Locking	Bolt FH M20x65	Nut M20 Locking
5 feet	122-369560	5 x	5 x	11 x	11 x
6 feet	122-369540	6 x	6 x	13 x	13 x
7 feet	122-369520	7 x	7 x	15 x	15 x
8 feet	122-369500	8 x	8 x	17 x	17 x

Bolt Mounting 5/8





Length	Adapter Plate	Bolt KH M16 x 55	Nut M16 Locking	Bolt FH M16x65	Nut M16 Locking
5 feet	122-369570	5 x	5 x	11 x	11 x
6 feet	122-369550	6 x	6 x	13 x	13 x
7 feet	122-369530	7 x	7 x	15 x	15 x
8 feet	122-369510	8 x	8 x	17 x	17 x

MOUNTING INSTRUCTIONS

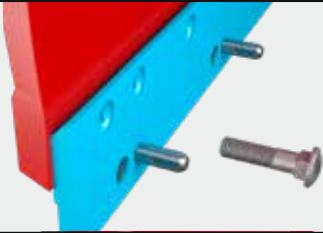

- WHEN CHANGING THE BLADES, YOU SHOULD WEAR GLOVES, SAFETY-GOGGLES AND -SHOES.
- GOOD ERGONOMIC POSITION TO MOUNT THE BLADES
- USE OUR SUPPORTING-TOOL

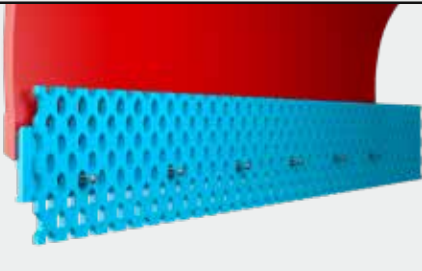
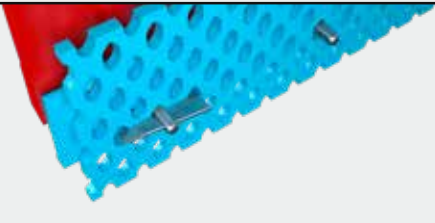
	<p>1</p> <p>FOR MOUNTING THE ADAPTER PLATE THE FOLLOWING IS NEEDED: BOLT 16X37 MM (5/8" × 1 1/2), "TRILOC" M16 (LOCK NUT 5/8"), APPROPRIATE WEDGE BOLT AND WASHER.</p>
	<p>2</p> <p>ATTACH THE BOLT 16X37 MM (5/8" × 1 1/2).</p>
	<p>3</p> <p>ATTACH THE WEDGE BOLT.</p>
	<p>4</p> <p>ATTACH THE WASHER AND "TRILOC" M16 (LOCK NUT 5/8").</p>
	<p>5</p> <p>REPEAT STEPS 2 THROUGH 4 UNTIL CORRECT AMOUNT OF WEDGE BOLTS IS INSTALLED. MAKE SURE THE WEDGE BOLTS "EYE" IS IN A HORIZONTAL DIRECTION.</p>
	<p>6</p> <p>ALIGN THE ADAPTER PLATE TO THE MOLD BOARD. MAKE SURE THE MOLD BOARD IS CLEAN AND FREE FROM DIRT.</p>

	<p>7</p> <p>ATTACH THE MOUNTING PLATES WITH BOLTS FH 16X65. FH 16X90 ARE NEEDED IF THERE IS A REINFORCED AREA ON THE MOLD BOARD. (IF MOTHER BOARD HOLES ARE 3/4", USE M20 BOLTS AND NUTS)</p>
	<p>8</p> <p>ATTACH THE "TRILOC" M16 (LOCK NUT 5/8").</p>
	<p>9</p> <p>ATTACH THE MOUNTING PLATES WITH BOLTS AT A DISTANCE OF 6" (152.5 MM) OR 12" (305 MM)</p>
	<p>10</p> <p>YOU CAN NOW INSTALL THE SHARQEDGES ON THE MOUNTING PLATE. THE BLADE SHOULD BE ATTACHED WITH THE BLADE PROTRUDING 2" FROM THE BOTTOM EDGE OF THE MOUNTING PLATE.</p>
	<p>11</p> <p>LOCK THE BLADE IN PLACE WITH APPROPRIATE WEDGES.</p>
	<p>12</p> <p>THE GRADER IS NOW READY TO BE USED</p>
	<p>13</p> <p>RETIGHTEN THE BOLTS AFTER A COUPLE OF HOURS OF OPERATION.</p>

RACE 150



BENEFITS:

- + CARBIDE
- + REDUCED VIBRATIONS
- + LONGER SERVICE LIFE
- + SMOOTH AGAINST THE ROAD
- + QUIETER

Race 150 is a plow blade with carbide sections soldered in short steel segments, which are then embedded in rubber.

This produces a plow blade with a long wear time thanks to the carbide. The rubber enables the plow blade to work more quietly and smoothly.

The embedded cutting blades provide smooth operation against the road surface. Ideal for both front and side plows on salted roads.

An alternative to regular carbide blades. Race 150 should be bolted into place with bolts and a Race150 mount.



RACE 150

Item. No	Name	W. mm	T. mm	L. mm	W. inches	T. inches	L. feet	Weight, kg	Weight, lbs	Bolt holes
122-261108	Race 150 152 x 22 x 610	152	22	610	6	0,86	2	8,52	18,78	2
122-261100	Race 150 152 x 22 x 915	152	22	915	6	0,86	3	12,78	28,17	3
122-261107	Race 150 152 x 22 x 1220	152	22	1220	6	0,86	4	17,04	37,56	4

RACE 150 CLAMP BAR

Item. No	Name	W. mm	T. mm	L. mm	W. inches	T. inches	L. feet	Weight, kg	Weight, lbs	Bolt holes
122-261114	Race 150 Clamp Bar 610	60	10	590	2,36	0,39	1,93	2,73	6,01	2
122-261116	Race 150 Clamp Bar 915	60	10	900	2,36	0,39	2,95	4,16	9,17	3
122-261117	Race 150 Clamp Bar 1220	60	10	1200	2,36	0,39	3,93	5,55	12,23	4

BRUXITE PLOW BLADES



Top punch
Ø 3/4" x 15

Center punch
Ø 3/4" x 15



Bruxite Plow Blades are manufactured from high-strength through-hardened special alloy steel, that maximizes wear life. When it comes to wear, hardness is everything, and the Bruxite Plow Blades are really hard, through and through, from edge to edge. The Olofsfors special alloy steel and heat treatment technology are what make these blades so tough and gives them their extreme hardness all the way through.

The edges are fully machined and shaped prior to the hardening process, which is crucial to the performance of hardened steel products. This production method results in blades with excellent performance, superior to that of wear parts cut from pre-hardened steel plate.

Olofsfors wear-resistant steel – optimum protection at the edges where wear is heaviest.

- + Hard and tough from edge to edge – maximum wear life
- + High precision in all dimensions – meets tough tolerance requirements
- + Systematic quality control
- + Fits all snowplows and grader blades
- + Available in serrated versions and other thicknesses

Width	Thickness	Length	Hardness	Note
200 mm (8")	16 mm (0,6") 25 mm (1")	1219 mm (4 feet) up to 6095 mm (20 feet)	500 HBW	Fits all snow plows

SERRATED & FLAT BLADES

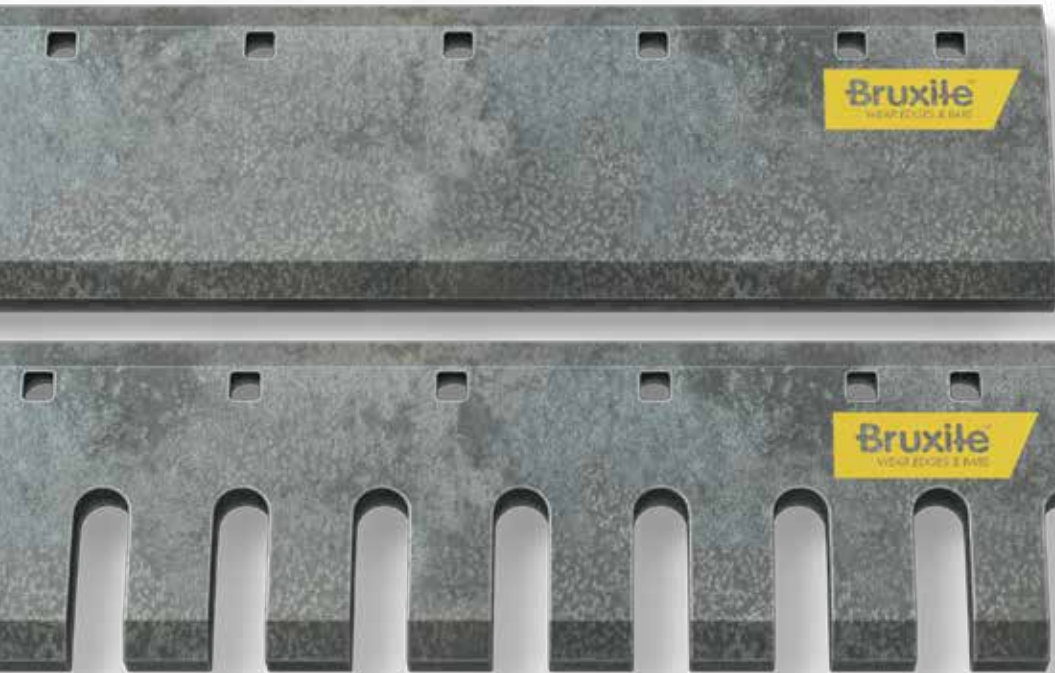

BENEFITS:

- + HEAVY-DUTY GRADER BLADES
- + 500 HBW
- + FITS ANY GRADER
- + AVAILABLE IN:
 - 8" TO 16" WIDTHS
 - 5/8" TO 3-3/4" THICKNESSES
 - 4' - 8' LENGTHS

Bruxite Blades are manufactured from high-strength through-hardened special alloy steel, that maximizes wear life. When it comes to wear, hardness is everything, and the Bruxite Blades are really hard, through and through, from edge to edge. The Olofsfors special alloy steel and heat treatment technology are what make these blades so tough and gives them their extreme hardness all the way through.

Olofsfors wear-resistant steel
- optimum protection at the edges where wear is heaviest.

- + Hard and tough from edge to edge - maximum wear life
- + High precision in all dimensions - meets tough tolerance requirements
- + Systematic quality control



FLAT BLADES											
OEM #	Thickness	Width	Length	Bolt Dim.	Width	Thickness	Length	KG	LB	Holes	OFAB-#
5/8" Plow Bolts											
4T2967	5/8"	8"	5	5/8"	200	16	1524	37,06	81,72	11	171M368700
4T2968	5/8"	8"	6	5/8"	200	16	1828	44,46	98,03	13	171M368701
4T2969	5/8"	8"	7	5/8"	200	16	2133	51,89	114,42	15	171M368702
4T2966	5/8"	8"	8	5/8"	200	16	2434	59,22	130,58	17	171M368703
4Z8129	3/4"	8"	3	5/8"	200	20	915	27,78	61,25	5	171M368705
4Z8119	3/4"	8"	4	5/8"	200	20	1220	36,84	81,23	6	171M368707
4T3034	3/4"	8"	5	5/8"	200	20	1524	45,76	100,90	11	171M368708
4T3007	3/4"	8"	6	5/8"	200	20	1828	54,91	121,05	13	171M368709
4T3036	3/4"	8"	7	5/8"	200	20	2133	64,07	141,27	15	171M368710
4T3035	3/4"	8"	8	5/8"	200	20	2434	73,12	161,23	17	171M368711
135-9692	1"	8"	4	5/8"	200	25	1220	45,42	100,15	9	171M368712
7T3497	1"	8"	5	5/8"	200	25	1524	56,76	125,16	11	171M368713
7T3499	1"	8"	6	5/8"	200	25	1828	67,85	149,61	13	171M368714
7T3498	1"	8"	7	5/8"	200	25	2133	79,19	174,61	15	171M368715
7T3496	1"	8"	8	5/8"	200	25	2434	90,38	199,29	17	171M368716
3/4" Plow Bolts											
4Z8120	5/8"	8"	5	3/4"	200	16	1524	36,85	81,25	11	171M368720
4T2971	5/8"	8"	6	3/4"	200	16	1828	44,21	97,48	13	171M368721
4T2970	5/8"	8"	7	3/4"	200	16	2133	51,61	113,78	15	171M368722
4T9603	5/8"	8"	8	3/4"	200	16	2434	58,89	129,85	17	171M368723
4T3033	3/4"	8"	6	3/4"	200	20	1828	54,56	120,30	13	171M368724
4T3032	3/4"	8"	7	3/4"	200	20	2133	63,68	140,41	15	171M368725
4T3037	3/4"	8"	8	3/4"	200	20	2434	72,68	160,26	17	171M368726
4Z8926	1"	8"	4	3/4"	200	25	1220	44,96	99,14	9	171M368727
7T3493	1"	8"	6	3/4"	200	25	1828	67,44	148,71	13	171M368728
7T3494	1"	8"	7	3/4"	200	25	2133	78,71	173,56	15	171M368729
7T3495	1"	8"	8	3/4"	200	25	2434	89,83	198,08	17	171M368730
4T6502	1"	10"	6	3/4"	250	25	1828	85,37	188,24	13	171M368731
4T6508	1"	10"	7	3/4"	250	25	2133	98,96	218,21	15	171M368732
4T6511	1"	10"	8	3/4"	250	25	2434	117,12	258,21	17	171M368733
4T8316	1 3/8"	10"	7	3/4"	250	35	2133	137,21	302,55	15	171M368734
4T8317	1 3/8"	10"	8	3/4"	250	35	2434	159,94	352,67	17	171M368735
104-3628	1 3/4"	10"	8	3/4"	250	45	2434	199,51	439,92	17	171M368735
140-6790	1"	11"	7	3/4"	280	25	2133	111,52	245,90	15	171M368736
4Z9186	1"	11"	8	3/4"	280	25	2434	127,27	280,63	17	171M368737
132-1086	1 3/8"	11"	8	3/4"	280	35	2434	177,68	391,78	17	171M368738
4Z9188	1 3/8"	12"	8	3/4"	300	35	2434	191,06	421,29	17	171M368739
128-2577	1 3/4"	13"	8	3/4"	330	45	2434	268,35	591,60	17	171M368741
1" Plow Bolts for 24H Graders											
109-3117	1 1/8"	13"	4	1"	330	30	1220	90,11	198,69	9	171M368750
109-3116	1 3/4"	13"	4	1"	330	45	1220	133,24	293,79	9	171M368751
132-1019	2 3/8"	13"	8	1"	330	60	2438	350,62	773,12	9	171M368752
135-9690	1 1/8"	16"	4	1"	400	30	1220	110,21	243,01	9	171M368753
138-6440	1 3/4"	16"	4	1"	400	45	1220	163,39	360,27	9	171M368754
	2"	16"	4	1"	400	50	1220	184,27	406,32	9	171M495500
135-9349	2 3/8"	16"	4	1"	400	60	1220	219,98	485,06	9	171M368755

SERRATED BLADES											
OEM #	Thickness	Width	Length	Bolt Dim.	Width	Thickness	Length	KG	LB	Holes	OFAB-#
5/8" and 3/4" Plow Bolts											
350-0179	3/4"	8"	6	5/8"	200	20	1828	44,02	97,06	13	171M368762
350-0181	3/4"	8"	7	5/8"	200	20	2133	51,32	113,16	15	171M368761
350-0180	3/4"	8"	7	3/4"	200	20	2133	51,00	112,46	15	171M368760
7T3600	1"	8"	4	3/4"	200	25	1220	38,24	84,32	9	171M368763
7T3601	1"	8"	5	3/4"	200	25	1525	47,83	105,47	11	171M368764
4Z8055	1"	10"	7	3/4"	250	25	2133	79,43	175,14	15	171M368767
4Z8056	1"	10"	8	3/4"	250	25	2434	90,71	200,02	17	171M368768
4Z8346	1 3/8"	10"	7	3/4"	250	35	2133	110,03	242,62	15	171M368769
100-4581	1 3/8"	10"	8	3/4"	250	35	2434	124,85	275,29	17	171M368758
104-3631	1 3/4"	10"	8	3/4"	250	45	2434	161,86	356,90	17	171M368532
134-1778	1 3/4"	13"	8	3/4"	330	45	2434	241,02	531,45	17	171M368531
1" Plow Bolts for 24H Graders											
138-6542	1 3/4"	13"	4	1"	330	45	1220	120,22	265,04	9	171M368533
	2"	16"	4	1"	400	50	1220	185,03	407,93	9	171M495505
135-9796	2 3/8"	16"	4	1"	400	60	1213	171,04	377,14	9	171M368530

CUSTOMER TESTIMONIALS

Sharq™



DALE PATTERSON

J.D. Irving, Canada: Woodlands (Sussex New Brunswick)

"I could not imagine how it would work here because we were wearing a 1" grader blade on average in 5 days. How would this thin blade last more than a few hours? To my surprise we are averaging about 3 weeks on a set of SharqEdges."

"Fuel consumption has dropped drastically from 24 L/hr on the old blades to 16 L/hr on the SharqEdges."

"We are able to recover more gravel and the holes allow some of the fines to stay on the road with the Sharq P300, something we could never do with conventional grader blades."

"We could only grade about 6 km a day with our old blades compared to 10+ km with the SharqEdges. Plus, the SharqEdges give us a safer road surface in summertime."

"We are very satisfied with Olofsfors SharqEdges, we are now running the system on 3 graders. We would never go back to the old way."



AL HOTEL / STEVE HULSMAN

Rocky View County, Canada: Rocky View, AB

"The fuel consumption with Sharq is 140–160 liters per day, and with regular grader blades its 200–240 liters a day."

"With regular grader blades you get a slippery surface, with Sharq P300 you get a scarified surface and that helps the sand and salt stay on the road."

"With regular grader blades you throw away 30–40% with Sharq P300 you throw away about 5%."

"Changing blades takes about 1–1.5hrs with regular grader blades, Sharq it takes you 15 min on the road."

"Sharq gives me about 100–120hrs and regular grader blades about 8–40hrs."

"When you get 4 times the wear life on the edges for 50% more cost there is an easy decision."



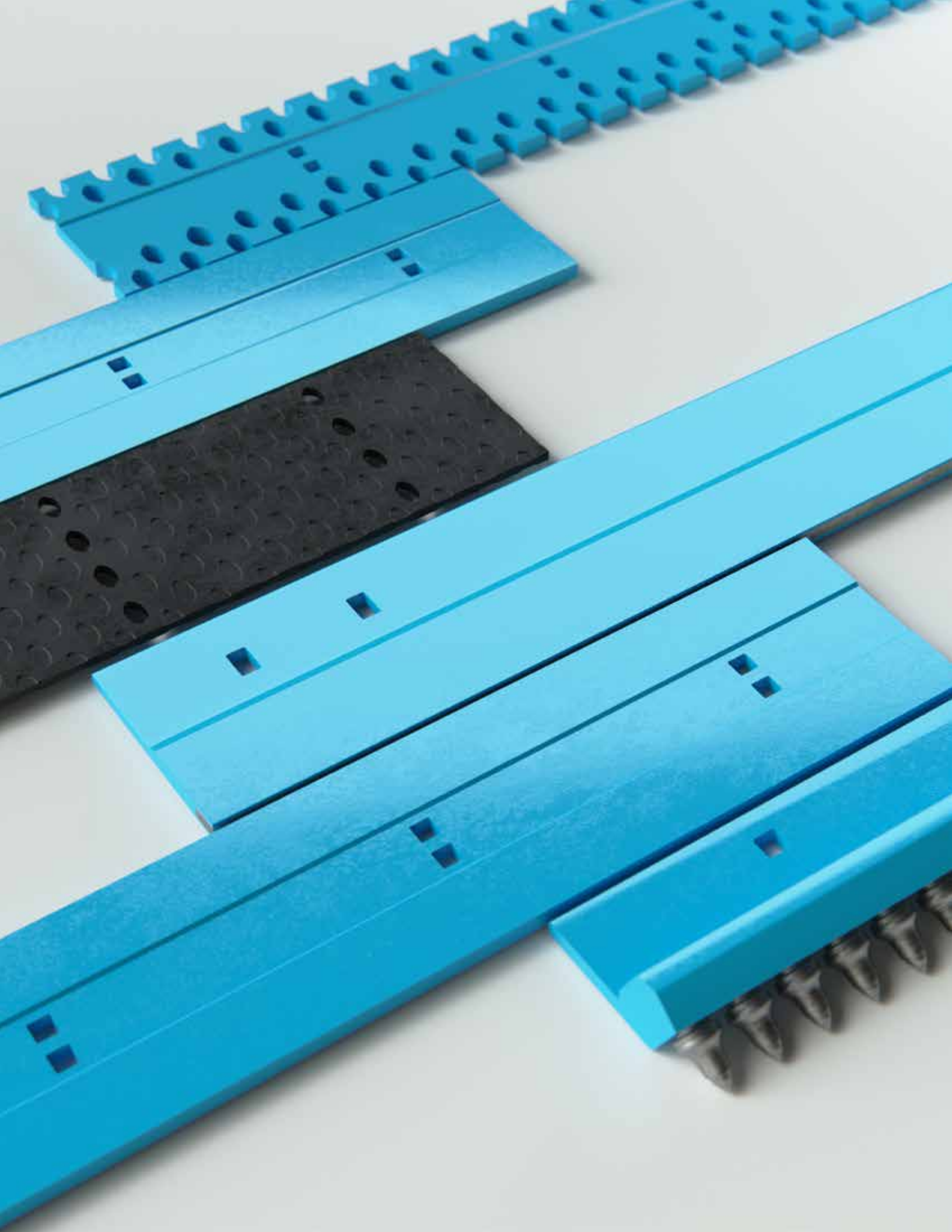

QUALITY AND KNOWLEDGE

The company of Olofsfors was founded in 1762. Since its conception more than 250 years ago, it has been producing world renowned high quality steel products. To this day, production is still at the same place located in the Northern part of Sweden. Three families have been involved since the beginning of our dynamic company: Jennings, Pauli and Wikstrom. The proud Wikstrom family have been owners since 1864. From 1762 and up until the late 19th century, Olofsfors produced steel from its own mill. Since the late 19th century Olofsfors has been focused on producing special and hardened steel products. This focus has produced the absolute best and highest quality of wear-resistant steel products in the world, resulting in Olofsfors becoming a contracted supplier to many well known Large Equipment Manufacturers. The Olofsfors business model still holds true today: produce high quality steel products through a focused mixture of knowledge and durability, adding value to our partners' products.

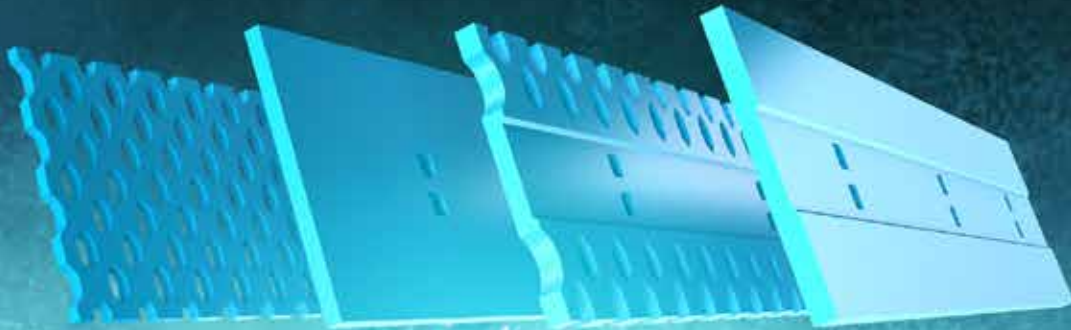

 **lofsfors**
Make your own way